



WHELEN AEROSPACE TECHNOLOGIES

Phone: (860) 526-9504

Internet: www.flyWAT.com

Sales/Service e-mail: info@flyWAT.com

Installation Guide/ICA:

Model 9085208

P/N:01-0790852-08

LED Anti-Collision Light Assembly

TSO-C96a
CLASS II, III;
APPROVED

The conditions and tests required for TSO approval of this article are minimum performance standards. Those installing this article either on or within a specific type or class of aircraft must determine that the aircraft installation conditions are within the TSO standards which include any accepted integrated non-TSO functions. TSO articles and any accepted integrated non-TSO function(s) must have separate approval for installation in an aircraft. The article may be installed only according to 14 CFR part 43 or the applicable airworthiness requirements.

WARNING: This product can expose you to chemicals including Methylene Chloride which is known to the State of California to cause cancer, and Bisphenol A, which is known to the State of California to cause birth defects or other reproductive harm. For more information go to www.P65Warnings.ca.gov.

OPERATING INSTRUCTIONS:

Operational Voltage: 28 VDC

(Operation from 21-32 VDC)

Average Input Current: 0.32 Amps

Pulse : 2.4 Amps

Flashrate: 45± 5 FPM

Weight:98 Lbs. (ref.)

EQUIPMENT LIMITATIONS: An approved Anti-Collision light assembly should be located so that their light will not impair the crews vision or detract from the conspicuity of the position lights. The baseplate must be mounted parallel to the vertical and horizontal centerlines of the aircraft to project the patterns properly. Certain types of aircraft may require additional testing.

AIRWORTHINESS LIMITATIONS: The Airworthiness Limitations section is FAA approved and specifies inspections and other maintenance required under §43.16 and §91.403 of the Federal Aviation Regulations, unless an alternative program has been approved. No airworthiness limitations are associated with the installation of the LED anti-collision light.

CONTINUED AIRWORTHINESS: The LED anti-collision light assembly is designed with multiple LEDs. If any one LED fail, the unit must be repaired or replaced. **Note:** To reduce eye strain use an optical filter such as dark glasses or a blue covering dome during LED inspection. Inspect the lens, replace if there is excessive scratching, pitting, discoloration or cracking. For additional lens maintenance detail see SAE ARP5637.

PERIODIC INSPECTIONS: An annual inspection shall be performed unless the OEM specifies a shorter interval.

INSTALLATION PROCEDURES: The following information provides guidelines for the installation of the WAT LED anti-collision light. Please refer to the OEM manual for your aircraft for specific removal and installation instructions.

1. Using the mounting detail information provided, prepare the aircraft for means to secure the light assembly.
2. Connect the inputs according to the chart shown. Connect the power lead to an appropriately sized breaker. Connections to be in accordance with FAA approved methods.
CAUTION: Do not touch the LED with either fingers or sharp objects. This could soil and/or damage the lens and effect the optical performance of the LEDs.
3. Using the appropriate hardware install the unit to the aircraft. Confirm proper gasket fit. Insure that all leads are clear of any obstructions and secured as required.
4. Place the light switches in the ON positions and verify proper operation of the light.
5. Check all avionics systems for interference from this installation.
6. A flight check should be performed by a properly certified pilot.
7. When necessary seal the light base to the aircraft. Apply single part silicone (RTV) or equivalent around the base of the unit and the countersunk hardware. Do not cover the drain hole.
8. If required, update aircraft records utilizing FAA Field Approval (Form 337) or equivalent.

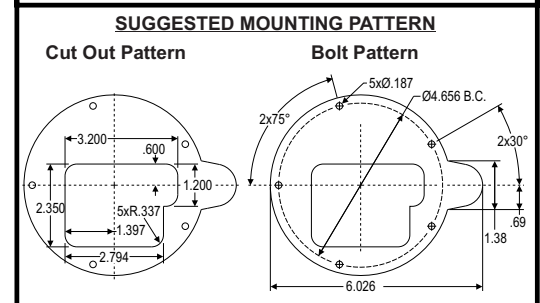
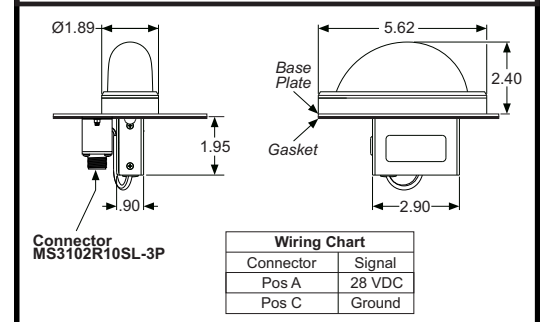
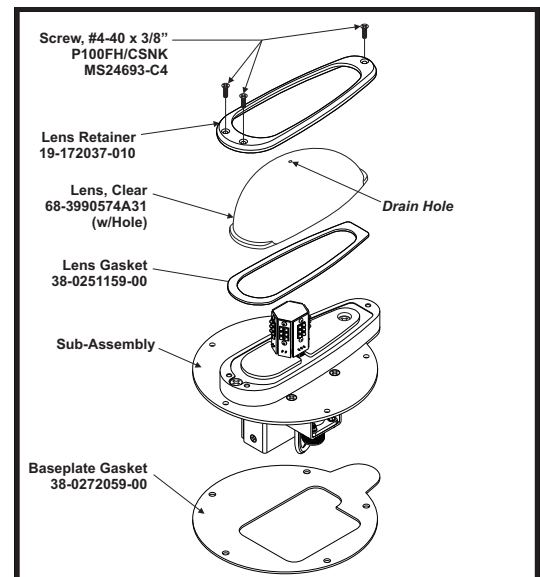

Aviation